

CAD FILE:

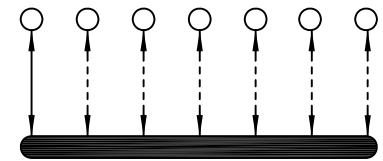

SCHEMATIC (SHORTING)

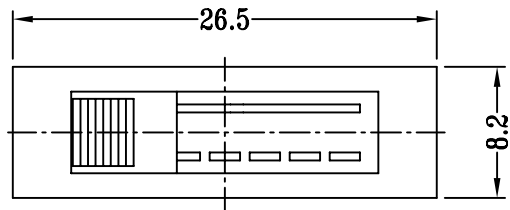
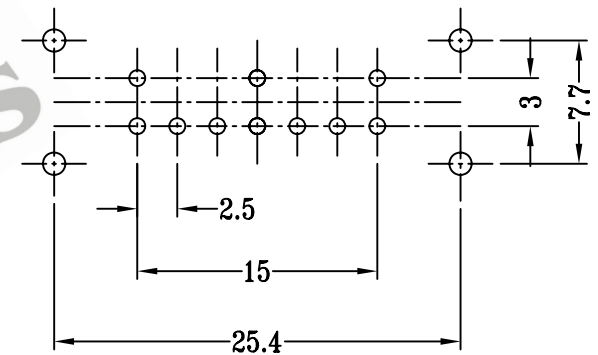
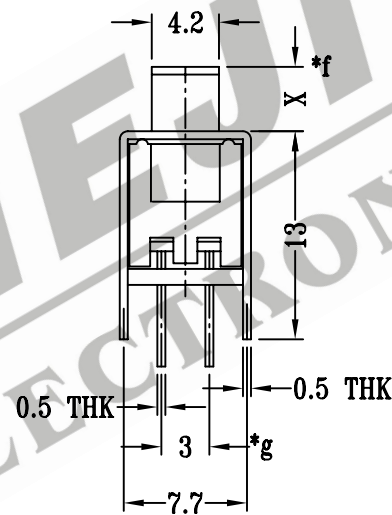
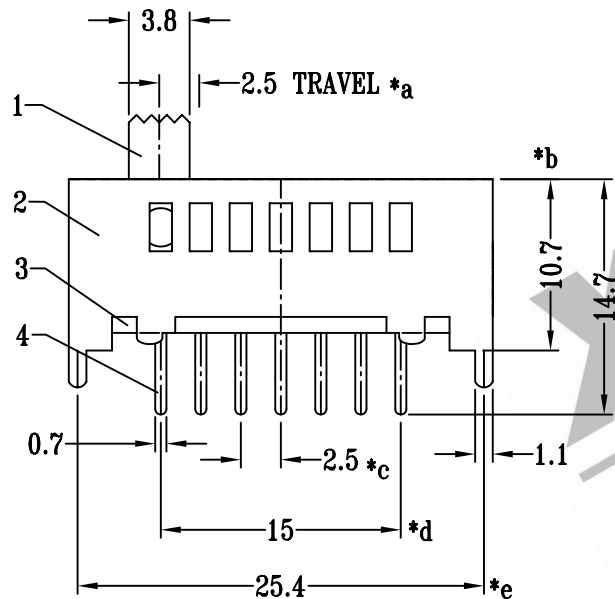

P.C.B LAYOUT

注:带\*表示关键尺寸(7个)

| NO. | PART NAME    | MATERIAL       | Q'TY | FINISHING                | TOLERANCE UNLESS SPECIFIED              | SHENZHEN XIEJIA ELECTRONICS CO.,LTD. |           |           |  |
|-----|--------------|----------------|------|--------------------------|---|--------------------------------------|-----------|-----------|--|
| 8   |              |                |      |                          |   | TITLE : VERTICAL SLIDE SWITCH        |           |           |  |
| 7   | STEEL BALL   | STEEL          | 2    | NATURAL                  | UNLESS SPECIFIED                        |                                      |           |           |  |
| 6   | SPRING       | STEEL WIRE     | 2    | TEMPER                   | WITHIN: 1.5±0.1mm                       | DESCRPTIONS                          |           | APPD.     |  |
| 5   | CONTACT CLIP | BRASS STRIP    | 1    | Ag PLATED                | OVER : 1.5±0.2mm                        | DRWG NO.: XJ-DR-SS17E01-00           |           |           |  |
| 4   | TERMINAL     | BRASS STRIP    | 10   | Ag PLATED OVER Ni PLATED |   | UNIT : MM                            |           |           |  |
| 3   | BASE         | PHENOLIC RESIN | 1    | NATURAL                  |   | SCALE: 2:1                           |           |           |  |
| 2   | FRAME        | STEEL STRIP    | 1    | Zn PLATED                |   | DWN. ZHOUYU                          |           | 2002-9-26 |  |
| 1   | KNOB         | POM            | 1    | BLACK                    |   | CHK'D FANGYING                       |           | 2002-9-26 |  |
|     |              |                |      |                          | ALL MATERIALS MUST BE COMPLIANT TO ROHS |                                      |           |           |  |
|     |              |                |      |                          | APPD. KANGXINAN                         |                                      | 2002-9-26 |           |  |